

CHANGES		
SYM	BY	DATE

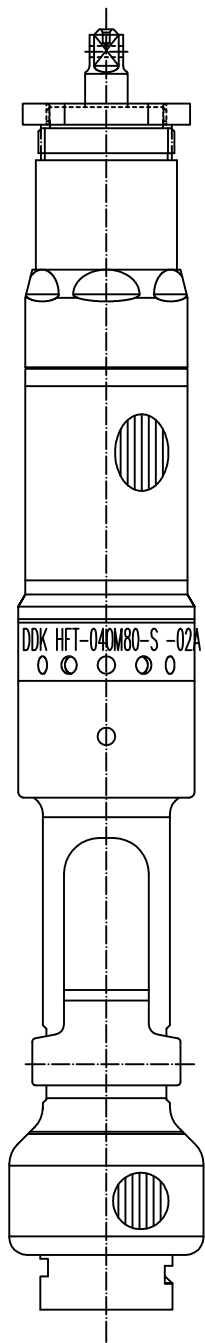
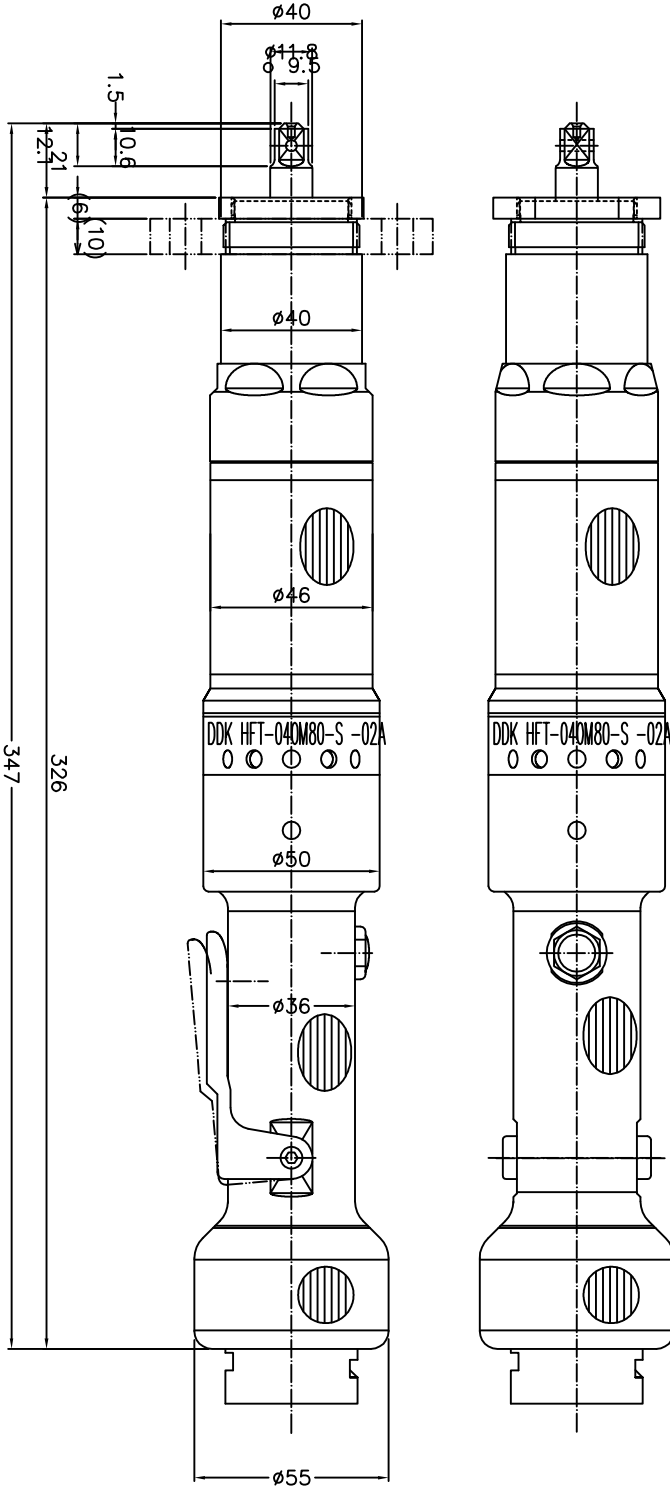
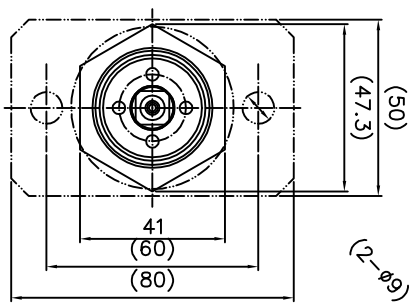

FULL SCALE TORQUE: 40Nm
 MAX FREE SPEED: 694 RPM
 WEIGHT: 1.43kg (3.2LBS)

TOLERANCE UNLESS OTHERWISE SPECIFIED
 INCH XX±.01
 METRIC XXX±.005
 XXXX±.005
 XXXX±.0005
 ANGLE±.5°
 XX±.127
 XXX±.0127
 ANGLE±.5°

1. DO NOT SCALE DRAWING.
 2. BREAK ALL SHARP CORNERS & EDGES EXCEPT AS NOTED.
 3. USE HI-COLLAR LOCKWASHERS UNDER ALL SOC. HD. SCREWS.
 4. APPLY LOC-TITE TO ALL SCREWS.

NOTICE OF PROPRIETARY RIGHTS
 The design concepts and engineering detail embodied in this drawing are the property of FEC INC. and are to be maintained in strict confidence; no element or detail of this drawing is to be disclosed nor used without the express written permission of FEC INC.

DESIGN	DATE	TITLE
FEC	FEC	OUTLINE DRAWING FOR
CHK BY	SAFETY OK	HFT-040M80-S-02A
FEC		
DATE	SCALE	
5/2/08	1:1	
SHEET	SHEETS	DRAWING NO.
1	1	HFT-040M80-S-02A

ANT	SYM	SHIT	NAME	PART #	FREQ

DESIGN	DATE	TITLE
FEC	FEC	OUTLINE DRAWING FOR
CHK BY	SAFETY OK	HFT-040M80-S-02A
FEC		
DATE	SCALE	
5/2/08	1:1	
SHEET	SHEETS	DRAWING NO.
1	1	HFT-040M80-S-02A

