

NEW PRODUCT

FUSION

HANDHELD NUTRUNNER

**STANDARD PISTOL TOOL
MODEL: HFT-015M50-P1**

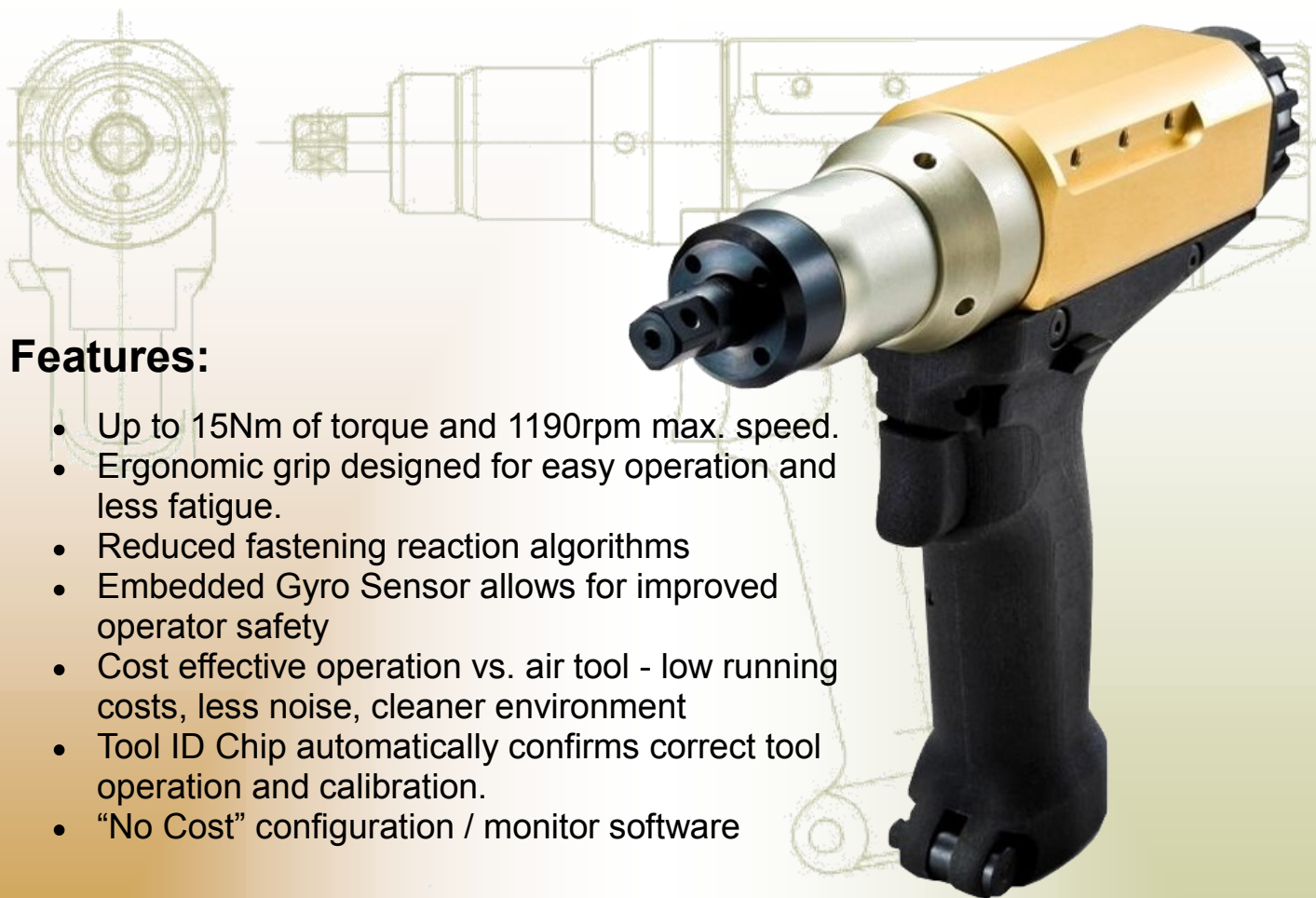

Features:

- Up to 15Nm of torque and 1190rpm max. speed.
- Ergonomic grip designed for easy operation and less fatigue.
- Reduced fastening reaction algorithms
- Embedded Gyro Sensor allows for improved operator safety
- Cost effective operation vs. air tool - low running costs, less noise, cleaner environment
- Tool ID Chip automatically confirms correct tool operation and calibration.
- “No Cost” configuration / monitor software



51327 Quadrate Drive Macomb, Mi. 48042 | Phone: (586) 781-2100 | Fax: (586) 781-0044

E-mail: sales@fec-usa.com

| Website: www.fec-usa.com

Specifications

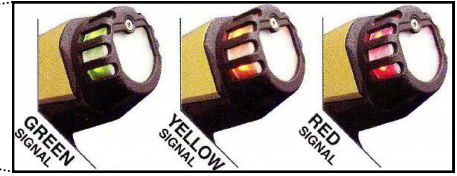
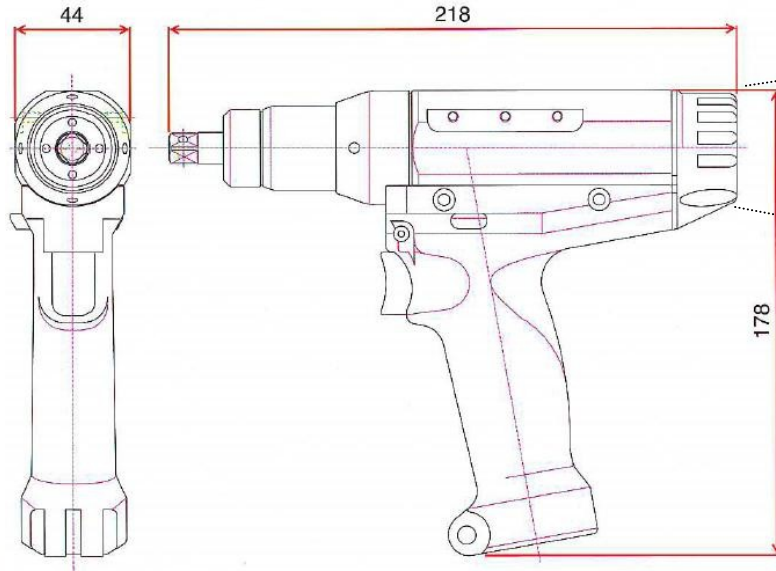

Large built-in status indicators are clear and visible from all directions.

Green: Accept
 Yellow: Bypass/Reverse
 Red: Reject

Tool Model	Maximum Torque [Nm (foot-pounds)]	Maximum Speed [r.p.m.]	Square Drive [mm (inch)]	Weight [kg (lbs.)]	Overall Length [mm]	Outer Diameter [mm]
HFT-015M50-P1	15.0 (11.06)	1190	9.5 (3/8)	1.1 (2.43)	218	R22

Accessories:

- A. Tool Hanger—Top Mounted
- B. Tool Hanger—Handle Mounted
- C. Trigger Lever

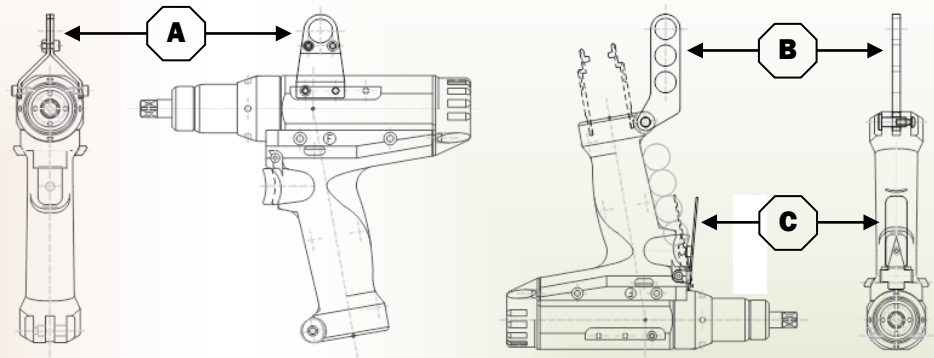

System Configuration

Item	Model #	Dimension [mm]	Weight [kg (lbs.)]	Remarks
Controller	HFC-EC-16	160Wx280Dx320H	8.6 (19)	100~230VAC, Single Phase, 50/60Hz.
Tool Cable	Main Cable Straight (5 & 10 meter)	C15-F7-M** (** = 05 or 10)		
Socket Tray	4 Socket	ST004	260Lx122W	Sockets up to 1.25" O.D.
	8 Socket	ST008	279Lx217W	Sockets up to 1.25" O.D.

